

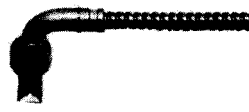

48PT1



48PT2



45CM1



69ND1

FIREYE® FLAME SCANNERS

INFRARED: 48PT1 and 48PT2

PHOTOCELL: 45CM1

FLAME ROD: 69ND1

For UV self-check scanners Scanners use SC101

For non self-check UV Scanners use SC102



DESCRIPTION

45CM1

The 45CM1 photocell scanner with #922 cell and Rajah stud terminal is designed for use in the blast tube on conventional pressure atomizing oil burners.

48PT1

The 48PT1 lead sulfide infrared scanner contains a high impedance detector and is designed to be used only on P-Series controls.

48PT2

The 48PT2 lead sulfide infrared scanner contains a low impedance detector and is designed to detect low flicker frequency IR signals from gas and light oil flames. It is designed for use on DSeries, Flame-Monitor, FlameWorx and MicroM controls.

69ND1

The 69ND1 flame rod is made of high temperature resistant metal and can be used only to detect gas flames. The rods come in 12, 18 and 24 inch lengths.



CAUTION: Fireeye scanners are for use only with Fireeye controls. Do not connect Fireeye scanners with controls not manufactured by FIREYE.



CAUTION: If component checking is required during burner operation for constantly fired burners, utilize the infrared flame scanner (48PT2) with associated AutoCheck amplifier. For Flame-Monitor systems use the EIR1, EIR3 or EIR2 and for MicroM systems use the MEIR1 or MEIR4.

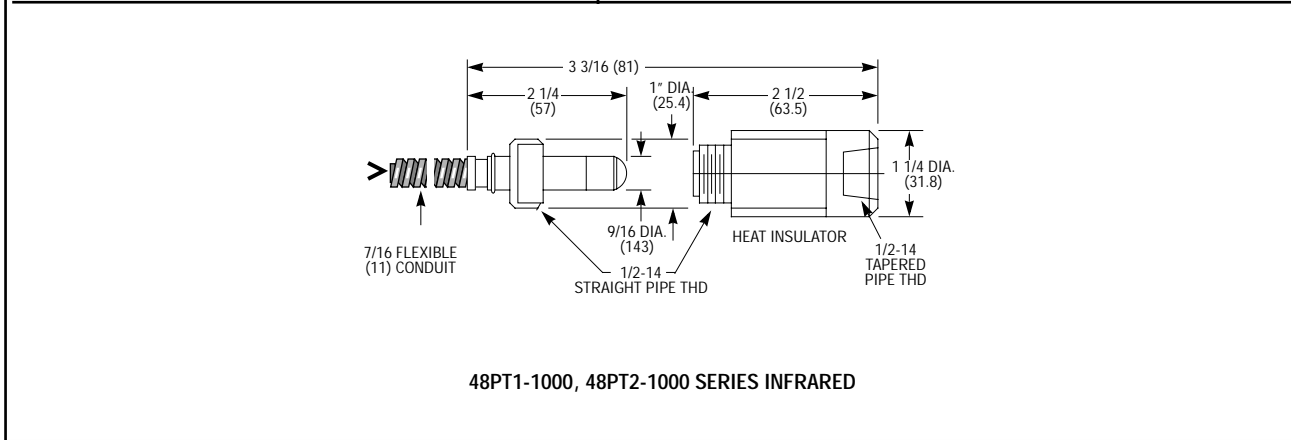
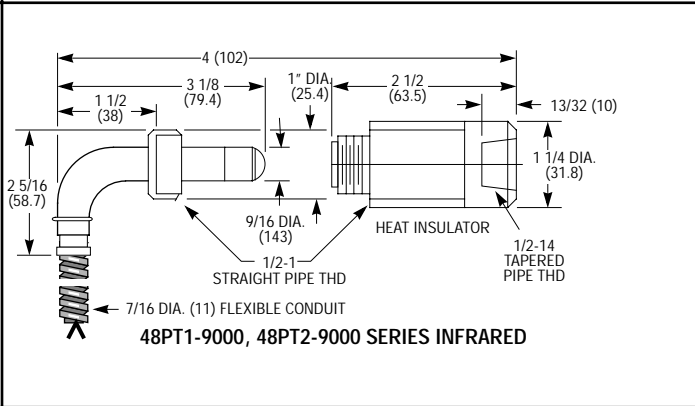
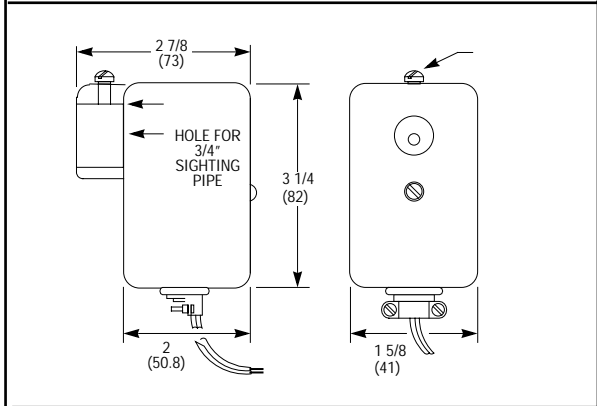
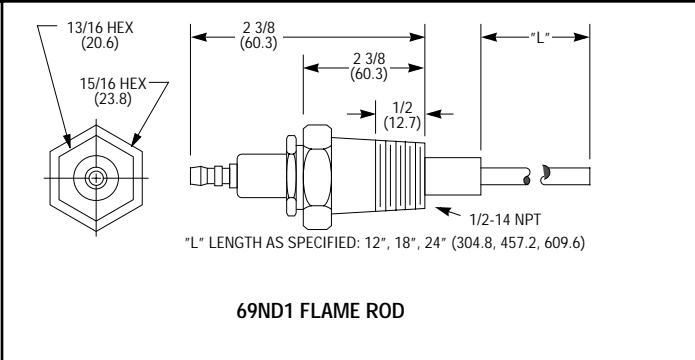
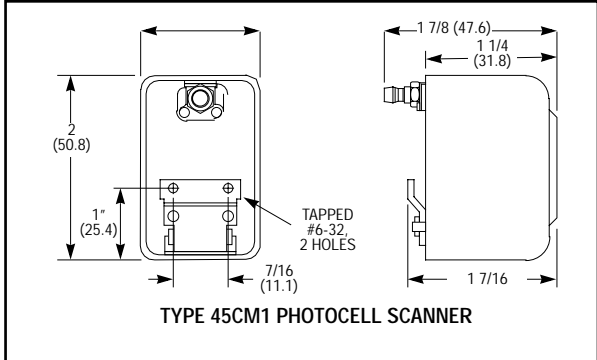

Scanner Model	Type	Approx. Volts Across Cell	Approx. Res.* of Cell	Ambient Temp. Limits
45CM1	Photocell	280-305 VAC	Infinite	165°F/74°C, -40°
48PT1	Infrared	125VDC	1.5 Meg. ohms	140°F/ 60°C, -40°
48PT2	Infrared	7-15VDC	20K - 80K ohms	140°F / 60°C, -40°
69ND1	Flamerod	280-305 VAC	Infinite	Tip 2460°F 1500°F/816°C, -40°

* Resistance measured with 20K Ohms/ Volt Meter
For proper Flame Signal Voltage see technical bulletin for the appropriate control.



PART NUMBER	DESCRIPTION	USE WITH
48PT1-1003 48PT1-1007 48PT1-9003 48PT1-9007 48PT1-9007W	IR Straight Head 8 feet (2440mm) leads IR Straight Head 4 feet (1220mm) Leads IR 90 deg. Head 8 ft. (2440mm) Leads IR 90 deg. Head 4 ft. (1220mm) Leads - 9007 Water Repellant	P-Series
48PT2-1003 48PT2-1007 48PT2-9003 48PT2-9007 48PT2-9007W	IR Straight Head 8 feet (2440mm) leads IR Straight Head 4 feet (1220mm) Leads IR 90 deg. Head 8 ft. (2440mm) Leads IR 90 deg. Head 4 ft. (1220mm) Leads - 9007 Water Repellant	C & D Series P-Series FLAME-MONITOR MicroM
35-69	Heat Insulator for 48PT Scanners	
69ND1-1000K4 69ND1-1000K6 69ND1-1000K8 45CM1-1000 45CM1-1000Y	Flame Rod 12 inches (305mm) 1/2 in. mount Flame Rod 18 inch (460mm) 1/2 in. mount Flame Rod 24 inches (710mm) 1/2 in. mount Photocell Scanner with filter Photocell Scanner without filter	C, D, M-Series MB Systems FLAME-MONITOR MicroM

For information on the 45UV scanners, see Bulletin SC-101.

For information on the UV1A, UV2, and UV8A scanners, see Bulletin SC-102.

SCANNER MAINTENANCE

48PT1 and 48PT2 Infra-red and 45CM1 Photoelectric Scanners

The viewing area of the scanner must be kept clean. Even a small amount of contamination will reduce the flame signal reaching the detector by a measurable amount. Wipe the viewing area routinely using a soft cloth dampened with concentrated detergent.

Type **48PT1** scanner includes a replaceable #4-128-1 cell.

Type **48PT2** scanner includes a replaceable #4-263-1 Firetron cell.

Type **45CM1** scanner includes a replaceable Fireeye part #4-230, Phototube #922.

Type **69ND1 Flame Rod**. Rods should be routinely replaced as they oxidize.

Flame Signal Strength. Routine observation of the flame signal strength or as read on the display of the FLAME-MONITOR will forewarn of any deterioration in the capability of the flame detector or its application.

Periodic Safety Check. It is recommended that a procedure be established to test, at least once a month, the complete flame safeguard system. This test should verify the proper operation of all limit switches and safety interlocks as well as flame failure protection and fuel safety shutoff valve tightness.

Rotation. It is recommended that control and scanner units purchased as spares be installed periodically.

Contacts. There are no accessible contacts in the Fireeye burner programming controls. Where contacts are used, their design assures long trouble-free life when the load circuits are maintained within the published load ratings.

Humidity. In areas of high humidity, the control chassis should be removed and placed in a dry atmosphere when the system is expected to be out of service for an extended period.



For scanner installation and wiring instructions, see the appropriate FIREYE technical bulletin for each control.

CONTROL	BULLETIN
FLAME-MONITOR	E-1101
D-Series	D-1020, D-30, D-4041
M-Series, UVM, TFM	C-400, C-401(E), C-402,
MB-systems	CC-82
MicroM	MC-5000
FlameWorx	MBD-1001



WARNING: FIREYE SCANNERS CAN BE USED ONLY WITH THE APPROPRIATE FIREYE CONTROL. DO NOT CONNECT FIREYE SCANNERS TO CONTROLS NOT MANUFACTURED BY FIREYE.

Minimum Pilot Test.

This test assures that the flame detector will not detect a pilot flame too small to reliably light off the main flame. The test should be made on every new installation, and following any repositioning of the flame detector. **THE MINIMUM PILOT TEST MUST BE ACCOMPLISHED BY A TRAINED AND QUALIFIED BURNER TECHNICIAN.**

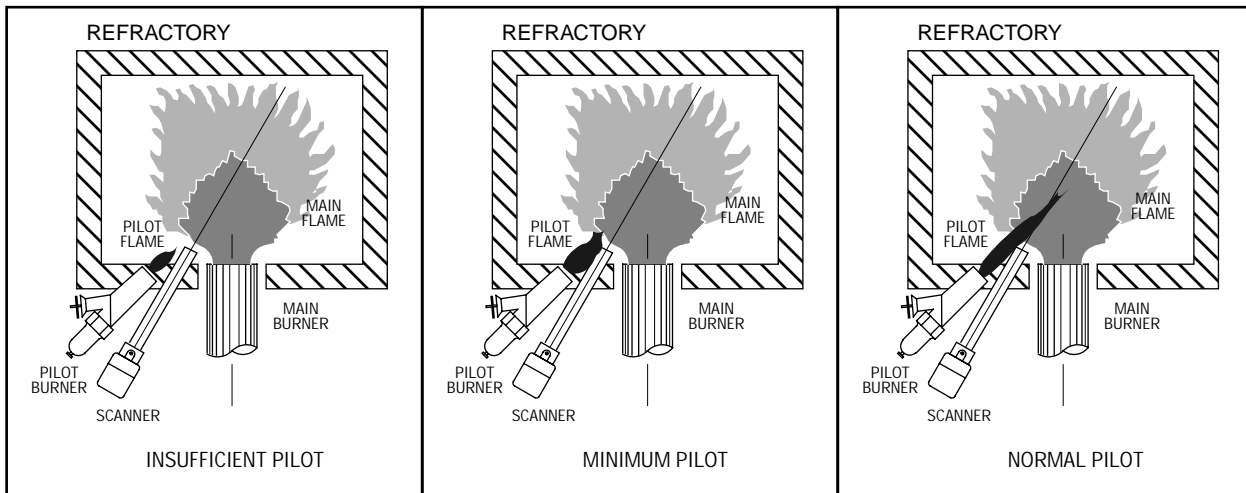

SPARK REJECTION TEST. CAUTION: The scanner must not sight the ignition spark directly or any part of the burner that can reflect the spark back to the scanner. The scanner must not see a pilot flame that is too small to reliably ignite the main flame. Test procedures vary according to the control used. See procedures as described in the technical bulletin for the control being installed.



FIREYE®
3 Manchester Road
Derry, New Hampshire 03038
www.fireye.com

SC-103
OCTOBER 2002
(Supersedes April 2002)

