

CHECK 507

HORIZONTAL SWING – BRONZE

300 lb. SWP-425°F-600 lb. WOG†-150°F

Bronze Regrinding Disc • Y-Pattern • Threaded Ends

SPECIFICATIONS

507	Conforms to: MSS SP-80. Type 3, Class 300, Threaded Ends.
-----	---

MATERIAL LIST

NO.	PART	MATERIAL	SPECIFICATION
1	Body	Cast Bronze	ASTM B 61
2	Cap	Cast Bronze	ASTM B 61
3	Disc	Cast Bronze	ASTM B 61
4	Lever	Cast Bronze	ASTM B 61
5	Pin	St. Steel	Commercial
6	Plug	Rod Brass	ASTM B 16
7	Disc Nut	Rod Brass	ASTM B 16

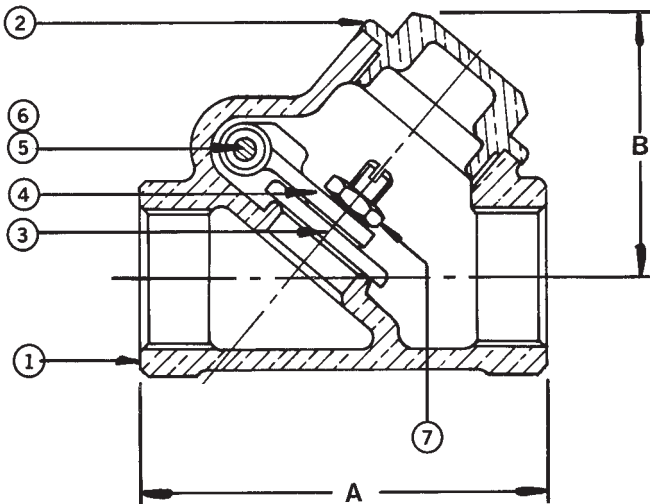

DIMENSIONS - INCHES / MILLIMETERS

Units	Size	A	B	C _v
Inches	1/4	2.25	1.63	2.3
mm	6.35	57.15	41.28	
Inches	3/8	2.25	1.63	4.3
mm	9.53	57.15	41.28	
Inches	1/2	2.63	1.75	7.2
mm	12.70	66.68	44.45	
Inches	3/4	3.00	1.94	13.0
mm	19.05	76.20	49.23	
Inches	1	3.69	2.50	22.0
mm	25.40	93.68	63.50	
Inches	1 1/4	4.38	3.00	39.0
mm	31.75	111.13	76.20	
Inches	1 1/2	4.63	3.31	56.0
mm	38.10	130.18	84.14	
Inches	2	5.88	4.00	92.0
mm	50.80	149.22	207.98	
Inches	2 1/2	7.00	4.75	150.0
mm	63.50	177.80	120.65	
Inches	3	7.88	5.50	240.0
mm	76.20	200.00	127.00	

† Non-Shock

Rev. 4

INNOVATION IN EVERY VALVE



MILWAUKEE VALVE

The information presented on this sheet is correct at the time of publication. Milwaukee Valve reserves the right to change design, and/or material specifications without notice. For the Installation, Operation and Maintenance Manual (IOM) see the engineering section on our website. For the most current information access www.milwaukeevalve.com

www.milwaukeevalve.com

Printed on recycled paper with soy ink. 05/05